

Tackling the increased density of 5G networks; the CROWD approach

M. Isabel Sanchez^{*†}, Arash Asadi^{*†}, Martin Dräxler[‡], Rohit Gupta[§], Vincenzo Mancuso^{*}, Arianna Morelli[¶], Antonio de la Oliva[†] and Vincenzo Sciancalepore^{*†||}

^{*}IMDEA Networks Institute, Madrid, Spain [†]University Carlos III, Madrid, Spain [‡]University of Paderborn, Paderborn, Germany [§]National Instruments, Dresden, Germany [¶]INTECS, Pisa, Italy ^{||}DEIB-Politecnico di Milano, Italy

Abstract—The significant growth in mobile data traffic and the ever-increasing user’s demand for high-speed, always connected networks continue challenging network providers and lead research towards solutions to enable faster, scalable and more flexible networks. In this paper we present the CROWD approach, a networking framework providing mechanisms to tackle the high densification and heterogeneity of wireless networks. The goal of CROWD is to design protocols and algorithms for very dense and heterogeneous wireless networks, which we call *DenseNets*. The mechanisms we propose include energy efficiency, MAC enhancements, connectivity management and backhaul configuration to contribute to the next generation of networks considering density as a resource instead of as an obstacle.

Index Terms—SDN, backhaul, interference, DMM, LTE

I. INTRODUCTION

We are witnessing a singularity in the deployment and usage of mobile radio networks. In fact, while pervasive computing and similar paradigms have been long theorised, e.g., [1], only recently the economic-technological advances have turned the dream into a reality. The number of wireless users is rapidly increasing, the offered load doubling every year. Moreover, expecting high-quality services and high data rates is becoming normal rather than exceptional. Examples include mobile video [2], which goes both directions, and cloud computing applications, whose growth has been predicted as sky-rocketing since a few years and will likely reach its climax soon [3]. All these factors led to expect an exponential increase of mobile data, in the order of $1000\times$ by 2020 [4].

Clearly, this growth cannot be sustained only by increasing the spectrum assigned to mobile radio networks. In fact, spectrum availability is already scarce in the ranges of practical interest, and spectral efficiency achieved by today’s technologies like LTE is already very close to Shannon’s limit. This leaves only one possible option: to densify wireless networks [5]. This trend can be observed, for example, in the characteristics of one of the key technologies for the upcoming 5G, the mmWave. This technology employs frequencies in the order of 60GHz, providing extremely high bandwidths in small islands of coverage. However, such densification cannot be done as a mere rescaling of existing protocols/networks because of the following primary reasons:

- Backhaul networks cannot be easily scaled down, since the installation of new cabled infrastructure requires more

substantial investments than the deployment of wireless access points, especially indoor [6].

- Existing network protocols have been designed to operate efficiently only for the current density levels, but they easily become a performance bottleneck when pushed further, e.g., too frequent mobility management messages are exchanged unnecessarily [7].
- Massive deployment of new base stations and interconnecting network elements creates an additional burden in terms of energy consumption [8].

CROWD, a collaborative project funded by the European Commission under the 7th Framework Programme, provides solutions to this issues by considering density as an asset. The CROWD project tackles the following key objectives:

- Bringing density-proportional capacity where needed, by increasing the density of points of access.
- Optimising MAC mechanisms operating in very dense deployments.
- Enabling traffic-proportional energy consumption, by modulating long-term activity cycles of each device, in both access and backhaul, based on traffic conditions.
- Guaranteeing mobile user’s quality of experience by designing smarter connectivity management solutions.

In this paper we describe the results obtained in CROWD and how these results will contribute to the upcoming 5th Generation of communication networks. The rest of this work is structured as follows. Section II introduces the architecture designed. In Section III we present the different key functionalities developed within CROWD, highlighting their relation and importance in the future 5G of communication networks. Section IV presents our test platform and finally Section V concludes this work.

II. ARCHITECTURE

The foreseen scenario for 5G is composed of a multitude of overlapping heterogeneous radio access networks (RANs). We will witness a change of focus on the deployment strategies of network operators, which will increasingly deploy Small Cell technologies to complement the already existing macro sites. Hence, two worlds will live together, large cells providing connectivity service, with low data rates available to the users but enabling global connectivity and transition between short range areas of high bandwidth. In this probable future, one

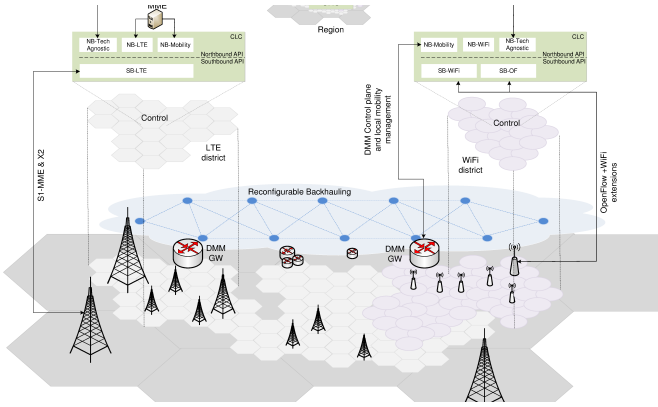

Fig. 1. CROWD architecture

of the key problems to be solved is the large amount of interference, even using different technologies to maximize spectrum utilization, generated by the large amount of overlapping cells. In addition, this future conglomerate of access networks requires smart management of its energy consumption, since large portions of the network will be un-used during some parts of the day. The simultaneous usage of several technologies and the short coverage of the Small Cells will also impact the mobility protocols and resources employed to handle user mobility, since the amount of handovers will largely surpass the handover rate in current networks. The CROWD project provides solutions to handle all the above challenges by enabling advanced techniques to take benefit of the density of the network. The CROWD architecture is presented in Fig. 1.

Due to the scalability problems arising from the control of a large density of elements in the RAN, CROWD has opted to base its architecture on the separation of control and data planes, following a Software Defined Networking (SDN) approach. Therefore, in CROWD we propose a dynamic, two-tier SDN controller hierarchy with two types of controller: 1) a CROWD Local Controller (CLC) which takes fast, short time scale decisions on a limited but fine-grained scope in a *district*, and 2) a CROWD Regional Controller (CRC) which takes long time scale decisions with a broader but more coarse-grained scope in a *region*. This two-tier approach allows us to better aggregate control information (i.e., reduce signalling overhead) when details are not required on a broader scope. A *district* consists of base stations (LTE eNBs and WiFi APs) and an interconnecting OpenFlow-enabled reconfigurable backhaul. A *region* is a logical area including several districts. CLC and CRC are the central parts of our overall architecture and enable the disjoint optimization of portions of the network while maintaining a coherent view of the status of the network in a central point. In addition this architecture is highly scalable since the portions of the RAN being controlled by the CLC can be done arbitrarily small. The need for a common and central point of coordination (the CRC) comes from the fact that considering only localised status to optimize the network could result in wireless chaos. For example, configuring Medium Access Control (MAC) parameters for WLANs only based on the scope of a single AP could result in a high level of harmful interference with a high number of surrounding APs. Similarly,

in LTE, extending the current neighbourhood coordination via the X2 interface to the high number of base stations present in DenseNets would result in unmanageable overhead. Therefore, we see a clear need for a paradigm switch on the control of network elements. Indeed, due to density and heterogeneity of DenseNets, we need a clear split between where the control decisions are taken and where the resulting control actions are enforced. The control decisions have to be taken on a scope that is broad enough to avoid a myopic scope on a very localised part of the network. In addition, the control actions have to be executed in a fast and precise manner to be effective. Thus the control actions cannot be executed on the same broad scope as the decisions are taken.

The controllers are the central pillar of our architecture, and CROWD functionalities are designed as applications running on top of an SDN controller, enabling the developer to control internal behaviors of the RAN elements through a set of extended APIs. This provides a high degree of flexibility, enabling the fast deployment of new functionalities into the network and reducing overall OPEX since no specialized management operations are required to deploy new functionality.

III. ENABLING TECHNOLOGIES TOWARDS 5G

A. Enhanced Wireless Mechanisms

CROWD offers algorithms and software for enhanced wireless mechanisms, which can be used not only to benchmark novel 5G proposals, but also to derive novel density-aware networking approaches. The two key technologies developed in CROWD to enhance wireless MAC mechanism are: (i) the control of the Almost-Blank SubFrame (ABSF) mechanism for enhanced Inter-Cell Interference Control (eICIC), and (ii) the optimization of Device-to-Device (D2D) communications for cellular offloading, opportunistic spectrum utilization and relay of traffic for devices with poor channel quality.

Efficient and lightweight control of ABSF has been designed by using game theory and optimization techniques. Differently from [9], where a centralized solution has been proposed, we exploit the cooperation amongst base stations to make our approach more practical and implementable in real networks. We delegate each base station to decide which set of users have to be scheduled in each subframe. Based on those decisions, each base station builds its ABSF pattern which is announced to the neighbor in a round robin fashion. However, we impose an upper limit to the number of subframes that each base station can use in a given time horizon. Such limit is dynamically adjusted by the central controller, CLC, using an *additive increase multiplicative decrease* mechanism, which has been largely proved to be optimal for such problems. The controller properly tracks dynamic changes occurred in the offered load experienced in the network. We call our scheme *CROWD Almost Blank Subframe technique (CABS)*. Fig. 2 shows an example of dynamic adaptation of ABSF patterns as the number of users per base station increases from 10 to 20 in a network with 7 base stations. Interestingly, *CABS* quickly reacts to network changes and achieves much better results than legacy solutions (“No ICIC” in the figure). *CABS* offers a trade-off between complexity and performance. In

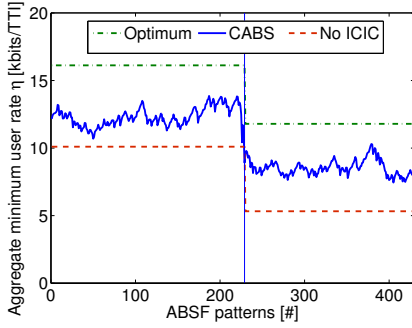

Fig. 2. Dynamic behaviour of *CABS* with 7 base stations and ABSF patterns of 70 subframes. The number of users is doubled abruptly after 230 subframes.

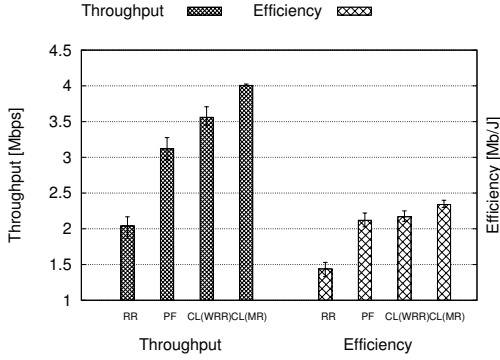

Fig. 3. Average per-user throughput and energy efficiency with DRONEE in network with 4 clusters consisting of 2, 4, 6, and 8 users, respectively.

fact, *CABS* is not far from the best performance achievable with ABSF (“Optimum” reported in the figure) and it has lower complexity and much less signaling overhead. *CABS* only requires to announce ABSF patterns in form of short bitstreams, while the computation of the optimal solution requires perfect knowledge of the channel quality reported by each user, which must be transferred to a central controller. Note that in *CABS*, the role of the controller only consists in dynamically regulating the maximum number of subframes that each base station might schedule.

As for the optimization of D2D strategies, CROWD has developed solutions for enhancing both WiFi and LTE-based systems by means of opportunistic and smart relay mechanisms [10], [11]. Fig. 3 shows an example of throughput and energy efficiency gain that can be achieved with D2D relay of traffic in LTE networks. The relay scheme developed in CROWD is called DRONEE, and is based on bridging LTE and WiFi Direct on mobile user’s devices and using clusters of users for scheduling operations [12], [13]. The figure shows that users receive the lowest throughput under round robin scheduling (RR) because they are scheduled irrespective of their channel quality. The proportional fair scheduler (PF) performs much better than RR, but is significantly outperformed by CROWD schemes CL(WRR) and CL(MR). CROWD D2D schemes are advantageous also in terms of energy efficiency, although they require the use of two wireless interfaces per mobile node.

B. Dynamic Radio and Backhaul Configuration

The enhanced wireless mechanisms described in the previous section impose two important requirements on the backhaul network: 1) the control functions for the enhanced wireless mechanisms, i.e. the CLCs, have to be instantiated close to the controlled network elements, i.e. base stations and access points, because of the low latency required by the control functions. 2) the backhaul network has to provide sufficient capacity between the control functions and the controlled network elements. Only if these requirements are met, the enhanced wireless mechanisms can operate effectively.

In order to meet the requirements, we have developed and implemented a mechanism called *dynamic radio and backhaul configuration*. This mechanism performs two tasks: 1) dynamic placement and instantiation of CLCs and 2) dynamic assignment of backhaul resources between the CLCs and the network elements. To perform these tasks the mechanism itself has to gather information on a regional scale and thus is implemented as a part of the CRC.

In our recent work [14] we have presented both an optimization problem and a heuristic algorithm to implement *dynamic radio and backhaul configuration*, based on optical WDM-PON backhaul networks. We have shown how we can both increase the feasibility of the enhanced wireless mechanisms and reduce the required backhaul resources.

For our evaluations (Fig. 4) we have compared the cases of having either 2 or 4 wavelengths available per link to assign in the backhaul network (parameter k). The most important results from our evaluation in [14] can be summarized as follows: Having the freedom to assign 4 wavelengths instead of 2 increases the feasibility of successfully instantiated districts with their CLCs (Fig. 4a). For different capacity demands per district (parameter d) we can identify turning points (dashed vertical lines) from which on the feasibility with 4 wavelengths is higher than the one with 2. If we look at the number of assigned wavelengths in the backhaul, in total (Fig. 4b) and on average per link (Fig. 4d) we can see that up to the turning points, the *dynamic radio and backhaul configuration* mechanism assigns the same number of wavelengths for both 2 and 4 available wavelengths, confirming that the mechanism does not assign additional wavelengths until necessary. Also, after the turning points the number of assigned wavelengths increases gradually and does not escalate immediately. We can thus conclude that the mechanism dynamically assigns wavelengths precisely according to the current demand. In Fig. 4c we can also see that our mechanism decreases the power consumption of the backhaul network compared to a static full assignment of all wavelengths, which is indicated by the horizontal dashed lines (upper one for 4 available wavelengths, lower one for 2). Considering the possible reduction of energy consumption by switching off unneeded WDM-PON equipment [15], our mechanism is also able to reduce the overall energy consumption of the backhaul network. This new *dynamic radio and backhaul configuration* mechanism ensures that enhanced wireless mechanisms, required for an efficient operation of the wireless part of the network, are feasible to use in backhaul networks with limited available resources.

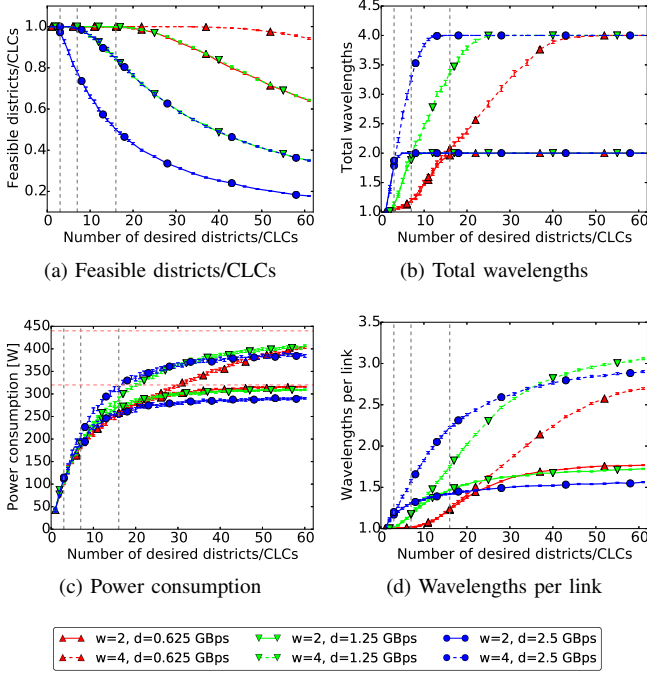

Fig. 4. Dynamic radio and backhaul configuration evaluation

C. Connectivity Management

Traditionally, IP mobility management has relied on a centralized approach, where an entity (the Home Agent in MIPv6 or the LMA in PMIPv6) manages all the mobility bindings. Such a centralized approach faces scalability issues, especially in a scenario as the one we consider. Distributed Mobility Management (DMM) is currently under investigation in the IETF [16] and opts for the distribution of the mobility anchors at the edge of the access network. In CROWD, we propose an architecture that empowers the DMM approach with a SDN-based control framework, as DMM lacks of a control plane to coordinate the networking elements involved.

The scenario envisioned for mobility management is presented in Fig. 5. It is composed of different single-technology domains or *districts*, similar to the localized mobility domains in PMIPv6. A district is composed of a dense deployment of Access Points, interconnected by an OpenFlow-enabled switched network, one or more gateways (DMM-GW) that connect the district to the Internet, and a CLC. The operations in the different districts are coordinated by the CRC. This architecture provides mobility at two different levels: *i*) intra-district layer-2 mobility, handled by the CLC, when the mobile node roams within a district and *ii*) inter-district layer-3 mobility based on DMM, coordinated by the CRC.

When a mobile node roams from one point of attachment to another within the same district, the CLC modifies the data path in the OpenFlow switched network to update the location of the MN and have the traffic forwarded to the DMM-GW from the new AP. In this case the CRC and the DMM-GW are not involved, enabling a faster handover procedure.

When a mobile node attaches to a district, the CLC checks with the CRC for previous registrations. If the mobile node is moving from one district to another, the CRC has the

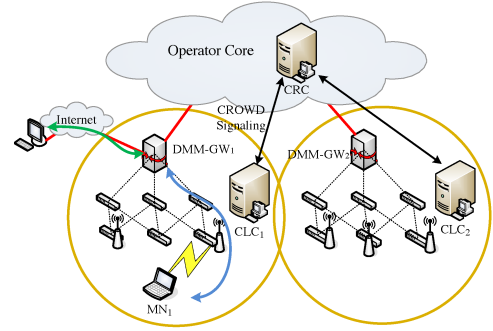

Fig. 5. SDN-based DMM architecture for mobility management.

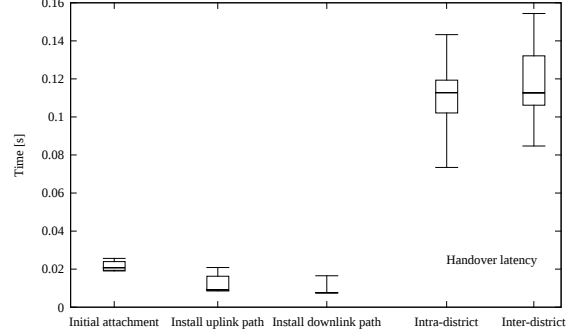

Fig. 6. Experimental results for mobility management prototype evaluation.

information about that mobile node in its Binding Cache (BC) and transmits it to the CLC. The CLC designates a DMM-GW to handle the mobile node's traffic in that district and informs the CRC. Then, in parallel, the CRC notifies the new location of the mobile node to the CLC in the previous district, CLC_1 in Fig. 5. With that information, CLC_1 configures an IP tunnel to DMM-GW₂ in DMM-GW₁, and the traffic to the prefix bound to the mobile node will flow through the tunnel. CLC_2 triggers the same configuration in DMM-GW₂ and configures the data path in the OpenFlow switched network so the traffic that arrives through the tunnel reaches the mobile node at its new location. Once the ongoing sessions are terminated, the binding to the previous district can terminate too and data traffic is not routed through the tunnel anymore. Assuming that most of the sessions do not have a large lifetime, most of the data traffic will be routed optimally, without tunneling.

We have implemented the proposed architecture for connectivity management in Linux boxes. We present in Fig. 6 the box and whiskers plot of the measurements for the characterization of the performance of our prototype. These metrics include signaling delay for initial attachment of the mobile node to a district and installing data paths, intra-district and inter-district handover latency.

IV. CROWD TESTBED FOR 5G

CROWD focuses on a wide variety of algorithms at all layers of the communication stack (LTE + WiFi) and aims not only to validate these concepts within a simulation framework but also in a lab environment, to illustrate their feasibility. As a result, CROWD imposes a wide-variety of requirements on the testbed activities within the project, e.g., to ensure modifiability/configurability at Physical, MAC layers of the stack to

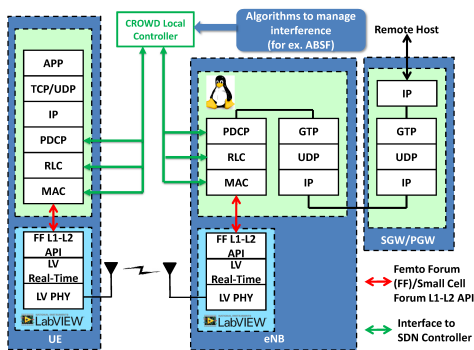

Fig. 7. LTE MAC/PHY SDN Architecture for CLC controlling eNBs.

allow flexible experimentation of ABSF and D2D algorithms. The proposed testbed architecture encompasses LTE and WiFi devices within the same software framework. In Fig. 7, we illustrate how proposed SDN controllers (CLCs, in this specific case) interact with LTE MAC/PHY interface of an LTE eNB to collect statistics regarding link performance in terms of throughput, channel state information, etc., while proposing eNB behavioral changes via a controller-MAC Scheduler API. In general, a CLC controller interacts with the MAC layer of eNBs to influence parameters related to scheduling; however, this interface can be easily extended to higher layers of the protocol stack. We use open source NS-3 LTE LENA stack [17] for implementing higher layers. Our proposal of using NS-3 for both simulations and prototyping has significant impact in reducing the time from simulations-to-prototyping dense LTE networks within a lab environment. The more detailed description of testbed architecture is illustrated in [18]. The high throughput LTE Physical (PHY) layer is implemented on Xilinx FPGA on NI PXI platform using LabVIEW. The main reason for using LabVIEW to implement PHY layer is the ease of use due to graphical design environment and also to meet the demanding high throughput/low latency requirements of LTE PHY layer. The scalable nature of the NI PXI platform allows to easily extend the current SISO OFDM PHY layer to multiple antenna/higher bandwidth configurations. We show an example use case to demonstrate ABSF algorithm in an indoor setting in Fig. 8, where we can see that USRP-RIO is used to implement PHY layer(eNB/UE) on Kintex 7 FPGA, whereas the higher layers are implemented on a generic Intel x86 machine and we use UDP for interfacing PHY/MAC interface. We can deploy several of these eNBs/UEs indoors to emulate dense deployments.

V. CONCLUSIONS

In this paper, we have described the solutions envisioned within the CROWD project to tackle the densification in the wireless access of future networks by presenting the novel mechanisms designed for connectivity management, energy-efficient operation, scheduling and random access MAC enhancements, including D2D schemes, and backhaul reconfiguration. We have presented the architecture, based on the SDN paradigm, designed to be scalable, flexible, energy-efficient and dynamically reconfigurable. We have introduced our testbed, which needs to include LTE and WiFi technologies and we have also presented experimental results from our

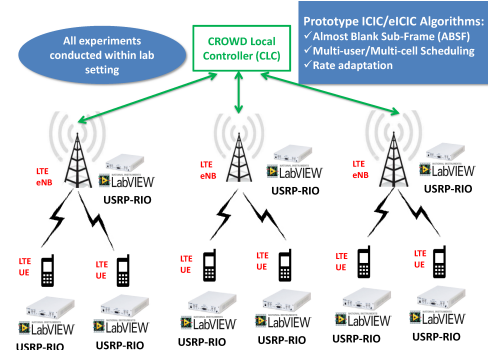

Fig. 8. LTE eICIC/ICIC Prototyping

early-stage implementation. The CROWD architecture and its controllers can be leveraged to push network performance towards the 1000x improvement in capacity and density targeted for 5G networks. Moreover, the modular and flexible controllers proposed in CROWD can be used to build new services in short time and to quickly reconfigure the network in negligible time, as per 5G objectives.

REFERENCES

- [1] D. Saha and A. Mukherjee, "Pervasive computing: a paradigm for the 21st century," *IEEE Computer*, vol. 36, no. 3, 2003.
- [2] K. Ma, R. Bartos, S. Bhatia, and R. Nair, "Mobile video delivery with http," *IEEE Comm. Mag.*, vol. 49, no. 4, 2011.
- [3] J. Zander and P. Ma'ho'nen, "Riding the data tsunami in the cloud: myths and challenges in future wireless access," *IEEE Comm. Mag.*, vol. 51, no. 3, pp. 145–151, 2013.
- [4] [Online]. Available: <http://www.qualcomm.com/1000x/>
- [5] K. Mallinson, "202 vision for lte," Report, June 2012.
- [6] W. Wang, G. Yu, and A. Huang, "Cognitive radio enhanced interference coordination for femtocell networks," *IEEE Comm. Mag.*, vol. 51, 2013.
- [7] K. Pedersen, P. Michaelsen, C. Rosa, and S. Barbera, "Mobility enhancements for lte-advanced multilayer networks with inter-site carrier aggregation," *IEEE Comm. Mag.*, vol. 51, no. 5, pp. –, 2013.
- [8] X. Xu, G. He, S. Zhang, Y. Chen, and S. Xu, "On functionality separation for green mobile networks: concept study over lte," *IEEE Comm. Mag.*, vol. 51, no. 5, pp. –, 2013.
- [9] V. Sciancalepore, V. Mancuso, A. Banchs, S. Zaks, and A. Capone, "Interference coordination strategies for content update dissemination in LTE-A," in *IEEE INFOCOM*, 2014.
- [10] A. Garcia-Saavedra, B. Rengarajan, P. Serrano, D. Camps-Mur, and X. Costa-Perez, "SOLOR: Self-Optimizing WLANs With Legacy-Compatible Opportunistic Relays," *IEEE/ACM Transactions on Networking*, no. 99, 2014.
- [11] A. Asadi, V. Sciancalepore, and V. Mancuso, "On the Efficient Utilization of Radio Resources in Extremely Dense Wireless Networks," *IEEE Communication Magazine Special Issue on Extremely Dense Wireless Networks*, Sep. 2014.
- [12] A. Asadi and V. Mancuso, "On the compound impact of opportunistic scheduling and D2D communications in cellular networks," in *Proc. of ACM MSWIM*, 2013.
- [13] —, "WiFi Direct and LTE D2D in action," in *Proceeding of IFIP Wireless Days*, 2013.
- [14] M. Dräxler and H. Karl, "Feasibility of base station coordination and dynamic backhaul network configuration in backhaul networks with limited capacity," in *European Wireless 2014 (EW2014)*, 2014.
- [15] K. Grobe, M. Roppelt, A. Autenrieth, J.-P. Elbers, and M. H. Eiselt, "Cost and energy consumption analysis of advanced WDM-PONs." *IEEE Comm. Mag.*, vol. 49, no. 2, 2011.
- [16] "IETF DMM WG: <http://datatracker.ietf.org/wg/dmm/charter/>."
- [17] "Overview of NS3 based LTE LENA Simulator." [Online]. Available: <http://networks.cttc.es/mobile-networks/software-tools/lena/>
- [18] R. Gupta, T. Vogel, N. Kundargi, A. Ekbal, A. Morelli, V. Mancuso, V. Sciancalepore, R. Ford, and S. Rangan, "LabVIEW based Platform for prototyping dense LTE Networks in CROWD Project," in *EuCNC*, 2014.